

WHAT IS A POSTER

The poster is a visual presentation of your paper and therefore you should aim to feature the focal points of your work. The delegates have a copy of your paper in the conference book of proceedings and can refer to this for details or further information.

Poster presentations should be kept **simple and clear** and mixture of text and graphics is recommended. Remember to caption your poster with the authors name and paper title.

TITLES AND FONTS

Titles and captions should be short and easy to read, a sans serif font like the one used in these instructions (Univers) is a good choice. Use large lettering as this means a number of people can read the poster from a distance without over-crowding. Large fonts are available via a laser printer or use photocopying enlargement as an alternative. For example:-

Headings
should be a
minimum of
50 point
size

Whereas, 25 point size
is fine for text

DIAGRAMS AND PHOTOGRAPHS

The use of diagrams, graphs and photographs give interest to your paper but they should only be used where they illustrate your argument. Photographs should have good contrast, sharp focus and if necessary an indication of scale. Graphs and diagrams should be enlarged so they are readable from a distance of 1 metre. This can be achieved by photocopy enlargement.

PAPER SIZE AND APPEARANCE

The overall size of the poster board for use at **INTERFLAM 2007** is

1 metre wide x 1 metre high.

You can use a single large sheet or several smaller sheets. Whichever, format you choose it is better to use matt rather than glossy paper.

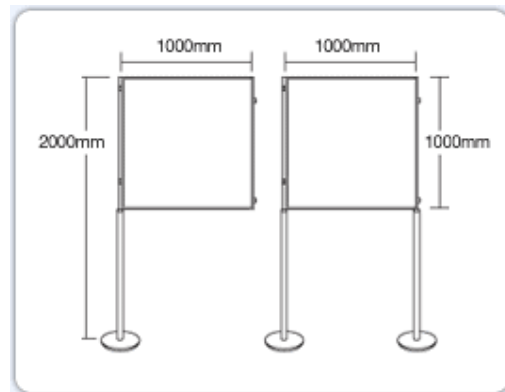

FIXING YOUR POSTER TO THE POSTER BOARDS

Velcro tabs are the **ONLY** way to fix your poster presentation to the boards. Please bring some with you but the Conference Organiser will have extra fixing material for your use.

PINNING UP YOUR POSTER AND PRESENTATION TIMES.

You can pin up your poster from 3pm Sunday afternoon and posters should be in place by morning break on Monday 3rd. The times when poster authors must be by their work are listed in the programme.